

Installation Guide

Version 01-08

DT

Swing Gate Opener

Features	1
Technical Specifications	
Mechanical Installation	2
Manual Release	5
Wiring	6
LED Diagram	
Wiring for Optional Accessories	7
Remote Control Setting	8
Self-learning	9
Solar System Installation.....	13
Gate Lock Installation	17
Flashing Light Installation	18



Standard
 Solar

1. Features

1. Manufacturer has patent for manual release mechanism. Use this feature in case of power failure, during installation or maintenance
2. Easy Self-learning feature (Page 9)
3. Commercial power & solar energy power source can be connected at the same time
4. Over current immediate stop function (A0~A1/ B0~B1)
5. Adjustable time of fast speed & slow speed (A2~A5/ B2~B5)
6. Adjustment of force during fast speed & slow speed (A6~A7/ B6~B7)
7. Auto Close function with adjustable closing time delay
8. Optional electric lock connection facility
9. Single or dual swing
10. Use max up to 50sets of remote controllers
11. DC 24V backup battery (Optional)
12. Flashing light AC 220V/110V & DC 24V (Optional)
13. Optional Device: DC24V gate lock, photocell, keypad, push button, extensional receiver box

2. Technical Specifications

DT

■ Electrical

Power Supply	AC110V~240V
Operating Voltage	DC 24V
Electronic Controller	Microcontroller Based
Safety Detection	Over Current Detection
Safety Barrier	Infrared Beam Sensor (Optional)
IP Rating	IP66

■ Mechanical

Swing Type	DT 3 Plus	DT 3
Max. Piston Stroke	430mm	350 mm
Max. Length of motor	1240mm	1036 mm
Max. Leaf's Weight	450 kg/ Leaf	400 kg/ Leaf
Suitable Leaf's Length	3.5 meter/ Leaf	3 meter/ Leaf
Frame Housing	Stainless Steel / Aluminum Alloy	
Driving Method	Screw Driven Piston Type	
Opening Degree	0 to 110 degree	
90 Degree Rotation Time	8 to 12 seconds	
Temperature	-25°C to +55°C	

DT

Swing Gate Opener

3. Mechanical Installation

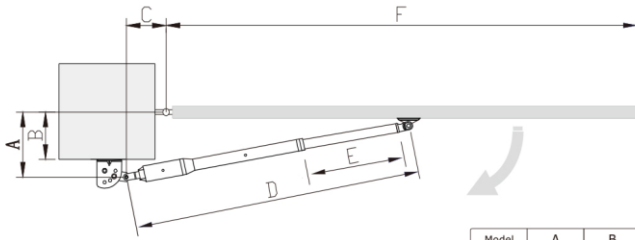

**Inward
Swing**

Measurement: mm

Model	A	B	C	D	E	F
DT3 Plus	≤275	≤200	≤180	1312	450	≤4000
DT3	≤225	≤150	≤130	1092	350	≤2500

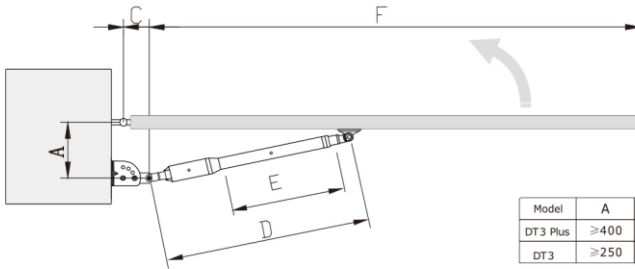

**Outward
Swing**

Measurement: mm

Model	A	C	D	E	F
DT3 Plus	≥400	≥180	862	450	≤4000
DT3	≥250	≥100	742	350	≤2500

Diagram Installation

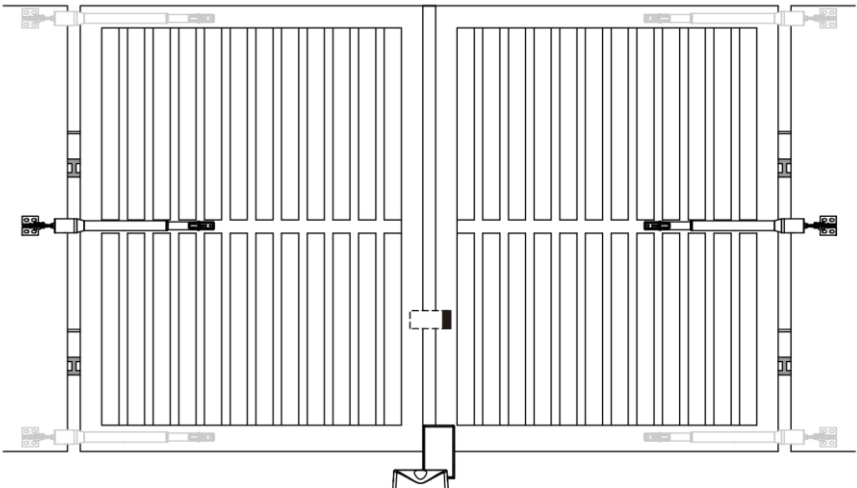

DT

Swing Gate Opener

Opener Dimension

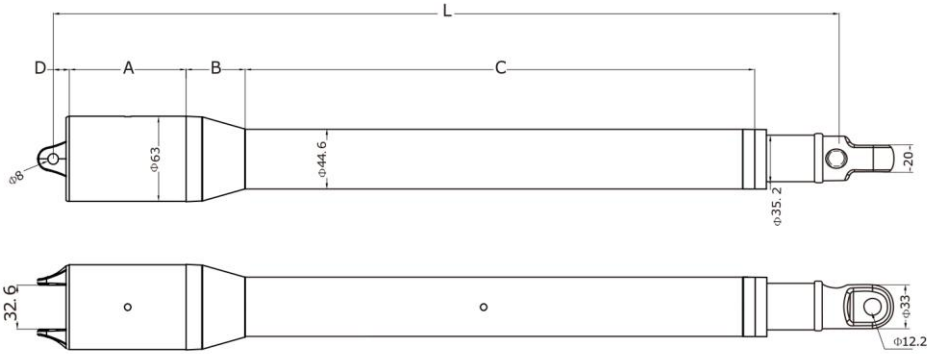

Measurement: mm

Piston Stroke	A	B	C	D	L
430	135	45	550	12.5	797/1247
350	135	45	425	12.5	686/1036

Bracket Dimension

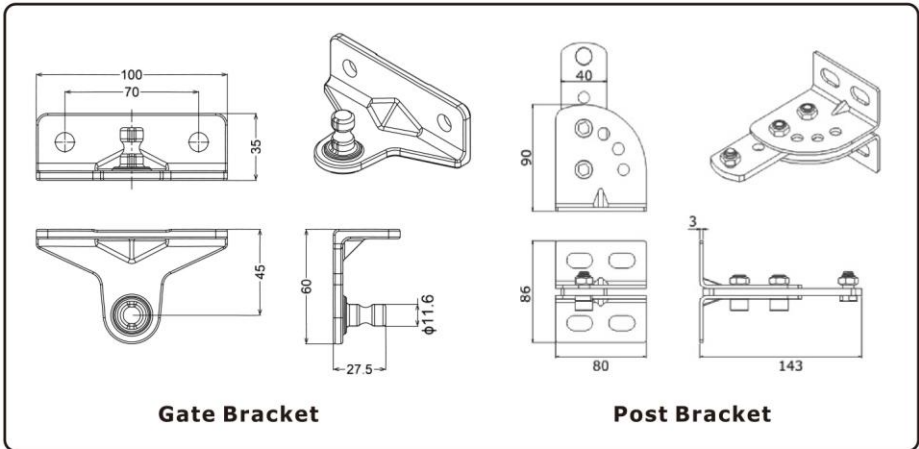

Gate Bracket

Post Bracket

Measurement: mm

DT

Swing Gate Opener

Installation Precautions

1. Please make sure there is some angle between the position of the gate bracket and the post bracket, and these two brackets should not be in parallel position.

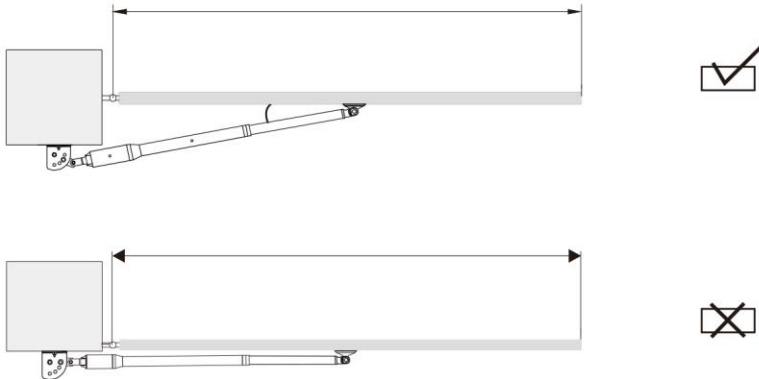

2. Make sure the position extend have at least 5mm allowance when the gate in opened/closed position.
3. There are two small holes in the swing arm motor, please make sure this side face down when do installation for water proof purpose.

4. Manual Release

In case of power failure, the operator can be disengage from the gate. Follow the directions below to release and rotate the operator to enable the manual release function.



1. Using Allen Key (Special Key) to unlock.
2. Separate motor and gear bracket.
3. Inversely repeat the previous action to lock.

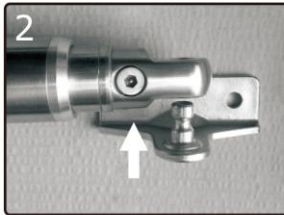
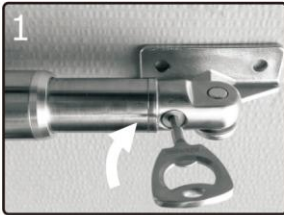

Control Box Setting

1. Wiring

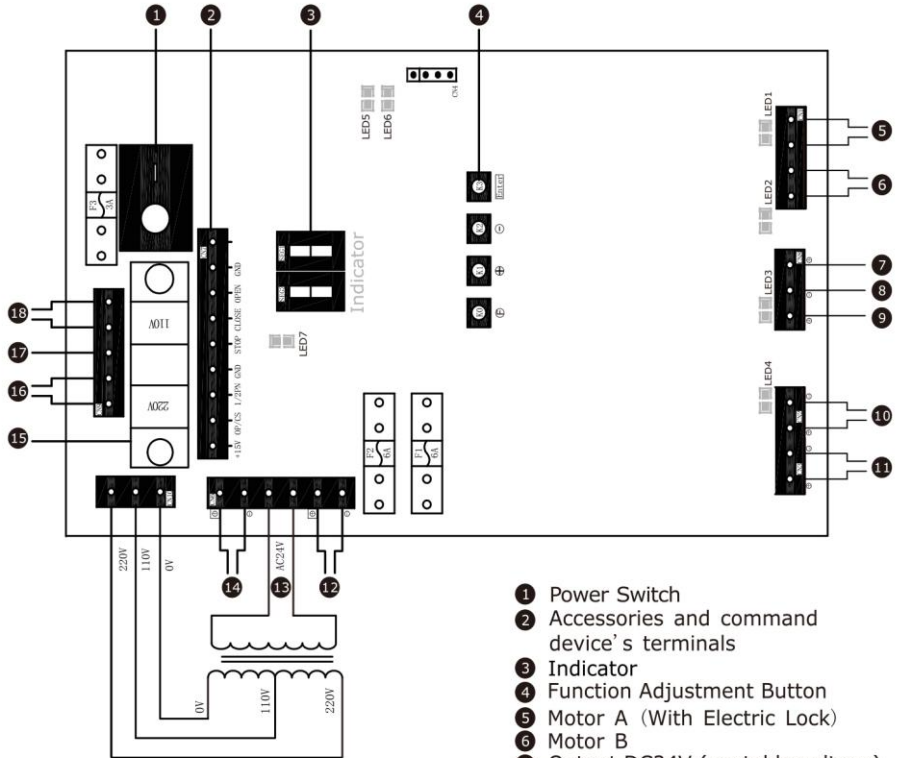

- ① Power Switch
- ② Accessories and command device's terminals
- ③ Indicator
- ④ Function Adjustment Button
- ⑤ Motor A (With Electric Lock)
- ⑥ Motor B
- ⑦ Output DC24V (unstable voltage)
- ⑧ 0V " - " output
- ⑨ Output DC15V stable voltage (load current can't be over 500mA)
- ⑩ DC24V Electric Lock
- ⑪ DC24V Flashing Light
** Photocell (see page 16)
- ⑫ Backup Battery(12V 9Ah X 2 in series)
- ⑬ Connector for adaptor
- ⑭ Solar Panel
- ⑮ Switch (AC 220V & 110V)
- ⑯ Power Supply (AC 220/110V)
- ⑰ Earthed
- ⑱ AC Flashing Light

LED Diagram

Power On, LED5 will blink.

- LED1 Motor A open LED
- LED2 Motor A close LED
- LED3 Motor B open LED
- LED4 Motor B close LED
- LED5 Power LED
- LED6 Received signal for remote control LED
- LED7 Push button LED

DT

Swing Gate Opener

2. Wiring for Optional Accessories

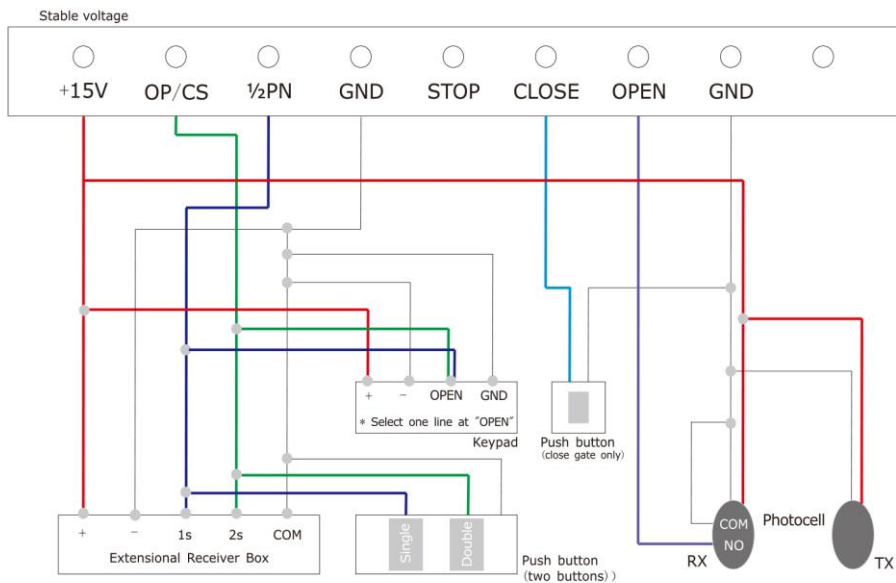

Item	+15V	OP/CS	1/2PN	GND	STOP	CLOSE	OPEN	GND	Reserved	Remarks
Description	Stable voltage output	Dual Open	Single Open	"-" & "Concentration line"	Stop	Close	Normally opening signal	"-" & "Concentration line"		
Extensional Receiver Box (single gate)	●		●	● ●						
Extensional Receiver Box (dual gate)	●	●	●	● ●						
Keypad (single open)	●		●	● ●						
Keypad (dual open)	●	●		● ●						
Push button (two buttons)		●	●	●						
Push button (one button)						●		●		close gate only
			●					●		single open
		●						●		dual open
Photocell (sender)	●							●		
Photocell (receiver)	●						●	● ●		

* ● "Means the connection port

DT

Swing Gate Opener

How to Connect the Motors

Motor A:

Connect the two wires from the motor to the "Motor A" terminals marked on the control board (see page 6). If you find the motor is operating in the wrong direction, It may be necessary to swap the wires of the motor around.

Motor B:

Repeat the above steps except connect to Motor B.

3. Remote Control Setting

3.1 Activating the Remote Control

Press and hold "F" button of approximately one second (without pressing the button of remote control) until the indicator appears "FF" and keep blinking, then release the "F" button.

Press any button on the remote control, if the indicator retain lighting, it means the remote controls are valid (50 remote controls can be set at most)

*Verify the remote control is activated by pressing the remote control button. The LED will be on/Off (see notes LED Diagram)

3.2 Erasing the code

Press and hold "F" button of approximately one second (without pressing the button of remote control) until the indicator appears "FF" and keep blinking, then release the "F" button.

Press and hold on "Enter" button on the PCB for over one second until the indicator retain lighting. Then all the remote controls are invalid.

****Pedestrian opening push "P" button to perform single swing opening**

Function adjustment button

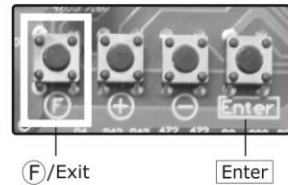

433MHZ Remote control

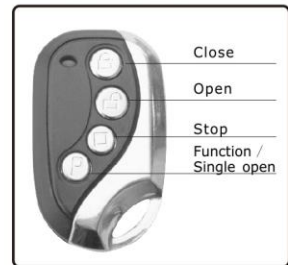

The remote control cyclic form is "open - stop - close"

4. Self-learning (Easy and Smart)

Checking before self-learning

1. Check the wiring of motors.
2. Check the manual release in locked position.
3. Make sure both gates are at fully opened position. For single gate , gate should be at fully opened position as well.
4. There should be hard stoppers at both fully opened positions and fully closed position.

STEP **1**

Self-learning setting (motor setting)

1. Press "F" button on the PCB , the indicator will show "C8",
(if no "C8" displaying, you can press "+" or "-" to reach it)
2. Keep pressing "Enter" button on the PCB above 3s till the indicator blinking, release the "Enter" button, then the motor will turn to self-learning mode.
3. The indicator will be "C8" and no blinking at the same time after self-learning finished, then you can use the remote directly.

- * Do not operate remote control during the above self-learning process. Press "F" button exit learning mode if meet emergency stop. Then repeat the self-learning process.

If you find problems of gate operation, in heavy windy days or with other obstacles, it's better to do "Motor setting" and Total timer adjustment manually.



indicator

PCB Function adjustment button

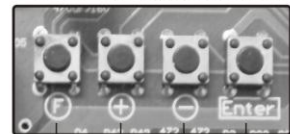

F/Exit + - Enter

STEP **2**

DT

Swing Gate Opener

PCB Manual Adjustment

After self-learning if needed manual adjustment to get optimum parameters, please following below :

If opening or closing doesn't reach required positions, you can increase the force during slow speed (A6,B6) by 10 and then repeat the self-learning process.

If speed is not slowing down at ends of the cycle decrease A6 and B6 by about 5 and then repeat the self-learning process.



Note:

1. After the above adjustment, still opening or closing doesn't reach designated position or slow speed no function , Following reason maybe caused:
 - a. The motor can not work well if the supply voltage instability. Please confirm it within $\pm 10\%$ for voltage fluctuation to study.
 - b. Advise to choose above 2.5 square mm with copper wire. It will be better to increase the wire diameter if long distance wiring.
 - c. Adjust the motor installed position.
2. In case if you have changed the parameters, make sure to restore factory default settings before proceed with self-learning procedure. (Set D2)

STEP **3**

DT

Swing Gate Opener

Function Adjustment

(Follow the steps below)

Step 1: Press "F" button, the indicator will show "C8"

Step 2: Press "+" button, it'll show in turn "C9, D0, D1, D2, A1, A2, A3, A4, A5, A6, A7, C0, C1, C2, C3, C4, C5", Press "-" button, it'll show reversely

Step 3: Press "F" button, after choose the item, the indicator will show numbers

Step 4: Press "+" or "-" button to select levels

Step 5: Press "Enter" button to confirm

Step 6: Press "F" button for return to previous configuration menu

Function Debug Form

Item	Name / Explanation	Setting Range	Default Setting	REMARKS
A0/B0	Intermediate Stop Function with slow speed. This refers to the sensitivity of gates when meeting obstacles during slow speed operation.	0~99	20	Lower setting means the gates will be more sensitive to stopping.
A1/B1	Intermediate Stop Function with high speed. This refers to the sensitivity of gates when meeting obstacles during high speed operation.	0~99	50	Higher setting means the gates are not as sensitive to stopping on hitting an obstacle.
A2/B2	Time of opening - slow speed. Low speed operating time during gate opening.	0~9.9s	9s	This is the time it takes to Open/Close the gate for the Slow Speed part of the sequence.
A4/B4	Time of closing - slow speed. Low speed operating time during gate closing.	0~9.9s	9s	
A3/B3	Time of opening - high speed. High speed operating time during gate opening.	0~99s	10s	This is the time it takes to Open/Close the gate for the Fast Speed part of the sequence.
A5/B5	Time of closing - high speed. High speed operating time during gate closing.	0~99s	10s	
A6/B6	Force of opening and closing - slow speed. Force adjustment for low speed operating during open and close.	0~99	56	This is the force the motor applies on the gates. If the gates are heavy, you will need more force to speed up the opening and closing of the gates. (Note: if the gates can open/close into position, you do not need to adjust the default settings.)
A7/B7	Force of opening and closing - high speed. Force adjustment for high speed operating during open and close.	0~99	99	
C0	Reverse swing of motor A. If you choose "0", the gate system will not have gate lock function or reverse swing operation. If you choose "1", the gate system will have gate lock function but no reverse swing operation. If you choose "2", the gate system will have gate lock function and reverse swing operation.	0~2	2	No need to adjust this if the gate installed has end stoppers.
	Electric lock.			
C1	Electric lock. If you choose "0", the gate system will not have gate lock operation after gate is closed. If you choose "1", the gate system will have gate lock operation after gate is closed.	0~1	1	When activated (Option "1"), the gates can't be pushed open.
	Motor delay setting. If you choose "0", only motor A working, motor B do not working If you choose "1", motor B will delay open during opening. If you choose "2", motor B will delay open during opening, motor A will delay start during closing. If you choose "3", motor B and motor A will start working at the same time.			
C2	Motor delay setting. If you choose "0", only motor A working, motor B do not working If you choose "1", motor B will delay open during opening. If you choose "2", motor B will delay open during opening, motor A will delay start during closing. If you choose "3", motor B and motor A will start working at the same time.	0~3	2	

DT

Swing Gate Opener

Item	Name / Explanation	Setting Range	Default Setting	REMARKS
C3	Time of auto close.	0~99s	0	
	If you choose "0", the gate system will not have auto closing function. If you choose "10", it means the gates will automatically close 10 seconds after completing its opening.			
C4	Time delay for opening, and delay for closing. During opening, motor B will open a little later than motor A During closing, motor A will close a little later than motor B	0.1~9.9s	2	
C5	Delay activating time for remote control button (for avoiding misoperation)	0~2	0	
	If choose " 0 ", normal operation			
	If choose " 1 ", delay 2 seconds then start the operation If choose "2", first press stop button for 2 seconds, then close /open button to activate the operation			
C8	Battery capacity display Below 30 = Battery soon will be run out 99 = Fully charged	0~99		
C9	Reserved terminal for maintainance and testing			
D0	PCB Model Number			Display PCB Model & Software version Number
D1	PCB Software version			
D2	Restore default setting " 09 " = restore factory settings		0	
C8	Self-learning feature			Press & hold "Enter" button to turn to self-learning mode

*Use this guide to help trouble shoot gates that are not operating properly. You can also set some of the auto open functions and delay functions using this guide.

1. For most of these functions, it's only necessary to adjust them if the system is not opening or closing as desired.
2. Default settings can be reset directly from the Power Control Box.
3. Please note that the gates open and close in the following manner: slow start, fast swing and slow finish. To adjust each of these speeds, refer to the chart above.



Solar System Installation

Solar Panel Installation

1. Measure and mark halfway along the long sides of both solar panel sides (170mm half way)
2. Place the holding brackets over this halfway point and mark the holes. Attach the plastic washers to the holding brackets and holding arms
3. Carefully drill the 4 holes with a 13/64 drill bit and be sure you don't drill into the glass. Use a piece of thin metal between the frame you are drilling and the white to protect it.
4. Place the holding brackets and use the 10mm screws and bolts to hold in place (You can also use the 4*13mm hex screws included).
5. Install the holding arm to the holding brackets with the 25mm screws and bolts. This can be done after you attach the holding arm to your fence post with the wiring. For maximum sun exposure, align the solar panel so the bottom is facing sunrise and the top is facing sunset.



*Recommend to use Ahouse solar panel when use solar system to ensure the motor could be normal operating.

Solar Panel Wiring Instructions

1. Using the supplied cables, connect one cable to the positive (+) terminal of the solar panel. Connect the other end of the same cable to the positive (+) terminal of the solar panel terminal in the control board (terminal 14 – see page 6).
2. Using the other supplied cable, connect it to the negative (-) terminal of the solar panel. Connect the other end of the same cable to the negative (-) terminal of the solar panel terminal in the control board (terminal 14 – see page 6).

Note: the solar panel markings are a little difficult to see. They can be found next to the terminals on the black plastic section of the panel.

DT

Swing Gate Opener

Battery Wiring Instructions

1. Using the supplied wire, connect the connector to the positive (+) terminal of one of the batteries. Connect the other end of the wire to the negative (-) terminal of the OTHER BATTERY.
2. Using the other wire, connect the connector to the positive (+) terminal of the battery. After the batteries are installed, the other end will be connected to the control board.
3. Using another wire, connect it to the negative (-) terminal of the battery. After the batteries are installed, the other end will be connected to the control board.

Note: make sure the bare ends of the wires do not touch together or do not touch the same metal surface at the same time.

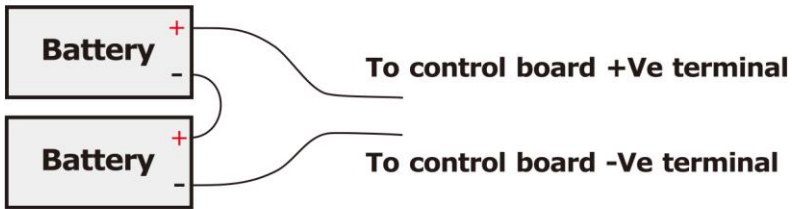

4. Install the batteries in the control box using cable ties as shown.



5. Connect the other end of the wire that is already connected to the positive terminal (+) of the battery to the positive (+) terminal in the control board for the battery (terminal 12 – see page 6).
6. Connect the other end of the wire that is already connected to the negative (-) terminal of the battery to the negative (-) terminal in the control board for the battery (terminal 12 – see page 6).

Battery Maintenance

Before use the batteries, please make sure that they are fully charged, it will lead to wrong operation if it is not fully charged, and need to check or replace the batteries by qualified person on a regular time basis.

* Recommend to use 2 pcs of 12V 9Ah Battery connection in series

Photocell Wiring during Solar Applications

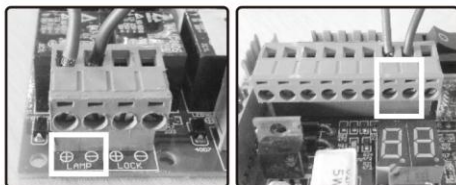
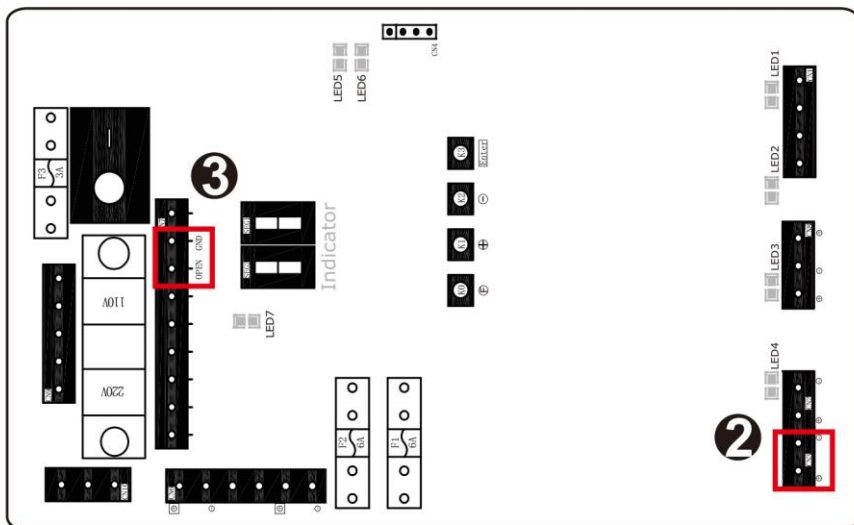
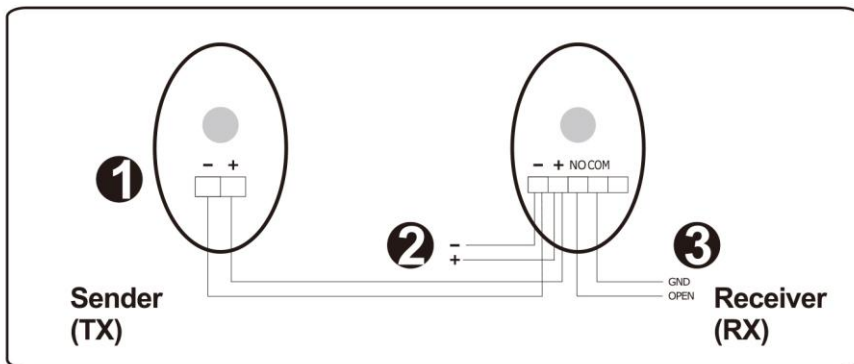

- 1 Connect TX "-" & "+" respectively to RX "-" & "+"
- 2 Connect RX "-" & "+" respectively to LAMP "-" & "+"
- 3 "NO" in RX connected to "OPEN" "COM" in RX connected to "GND"

Instructions for photocell

During gates closing, if the photocell detect any obstacles, the gates will stop immediately and then reverse back. Only until the obstacles be removed, the gates will operate according to new command.

DT

Swing Gate Opener

Gate lock installation

Model: Ds218

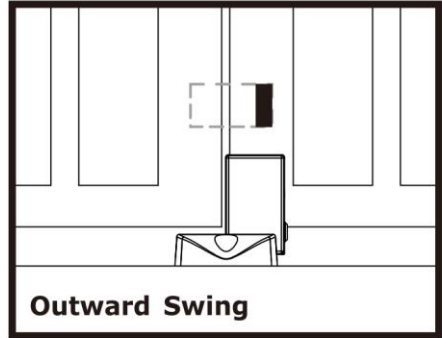
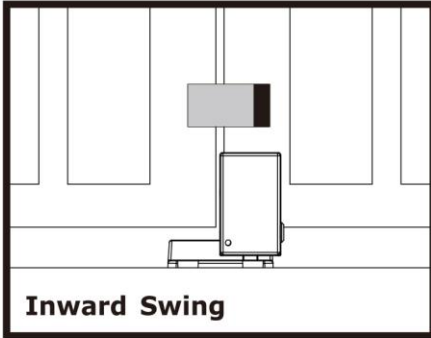

Installation

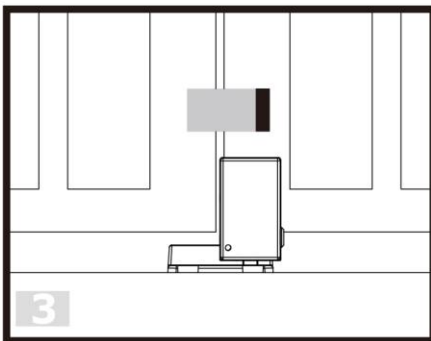
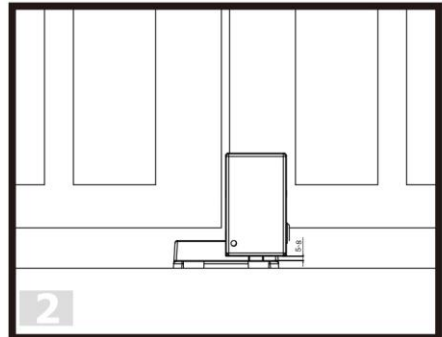
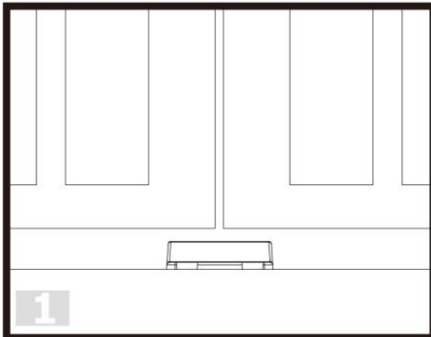

1. Install the stopper
2. Fix the lock body onto the first moving side of the gate leaf, make sure there is at least 5 to 8 mm space between the stopper location hole surface & the bottom of lock body.
3. Install the stopper plate in corresponding position onto the same leaf which installed with lock DS218, this is to make sure when 2 leaves are closed, the stopper plate can limit the leaf which cannot opened either.

* The lock bolt pin must be in vertical position with the bolt pin of the stopper .

DT

Swing Gate Opener

Flashing light installation

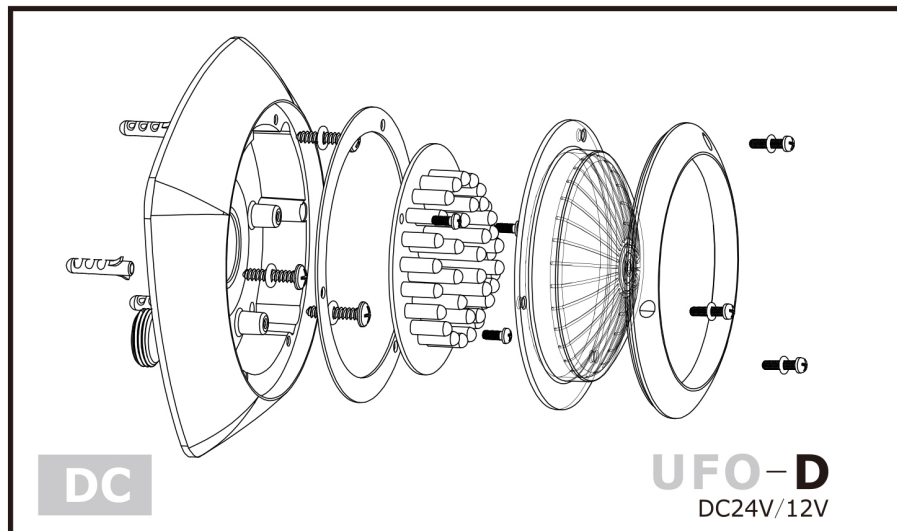
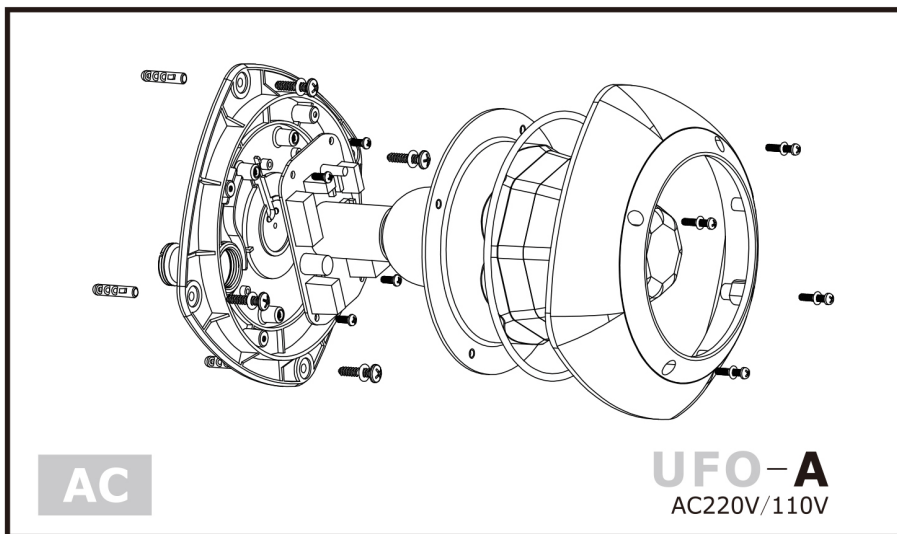

If using solar systems, connect with DC24V
*wiring for flashing light, (see page 6)

DT

Swing Gate Opener

